

# ***GSM-VAC4+LITE***

***VOICE & SMS GSM ALARM  
COMMUNICATOR***

---

***INSTALLER'S MANUAL  
V 1.0***

## TABLE OF CONTENTS

---

1.1 RECORDING MODE.....	8
1.2 PLAY.....	8
1.3 PROGRAMMING TELEPHONE NUMBERS - TN.....	9
1.3.1 TN remote programming by SMS.....	10
1.4 PROGRAMMING INPUT STATUS - IN.....	10
1.4.1 IN parameter remote programming by SMS.....	11
1.5 DELAY BEFORE DIAL – DD.....	11
1.5.1 DD remote programming by SMS.....	11
1.6 INPUT FILTER PARAMETR – ID.....	12
1.6.1 Programming table to define the value of the input filter.....	12
1.6.2 ID parameter remote programming by SMS.....	12
1.7 PROGRAMMING OUTPUT STATUS - OS.....	13
1.7.1 Programming table for output status.....	13
1.7.2 OS remote programming by SMS.....	13
1.8 DIRECT ALARM OUTPUT – OD.....	14
1.8.1 Programming table for OD – direct alarm output.....	14
1.8.2 OD remote programming by SMS.....	14
1.9 INPUTS AND TELEPHONE NUMBERS LINKING.....	14
1.9.1 Programming table for linking the inputs and telephone numbers – LN.....	15
1.9.2 LN remote programming by SMS.....	15
1.10 MAIN POWER LOST AND TELEPHONE No. LINKING – LN5.....	15
1.10.1 Programming table for the MAIN POWER LOST and telephone numbers linking.....	16
1.10.2 LN remote programming by SMS.....	16
1.11 LOW BATTERY AND TELEPHONE No. LINKING – LN6.....	16
1.11.1 Programming table for LOW BATTERY and telephone numbers linking.....	16
1.11.2 LN4 remote programming by SMS.....	17
1.12 MAIN POWER LOST FILTERLTER PARAMETR - MAIN .....	17
1.12.1 Programming table for “MAIN POWER LOST” filter – MAIN.....	17
1.12.2 “MAIN POWER LOST” filter remote programming by SMS.....	17
1.13 INPUT TIME WINDOW – IT.....	18
1.13.1 The input time window remote programming by SMS.....	18
1.14 INPUT TRIGGER COUNTER BEFORE BLOCK - AR .....	18
1.14.1 The input trigger counter before block remote programming by SMS.....	19
1.15 SECURITY LEVEL - SL.....	20
1.15.1 Programming table for security level definition – SL.....	20
1.15.2 SL parameter remote programming by SMS.....	20
1.16 PRE-PAY CARD CREDIT AND VALIDITY INFORMATION.....	21
1.16.1 Programming pre pay card credit and validity string.....	21
1.16.2 CC parameter for remote programming.....	21
1.17 GSM-VAC4+ LITESET-UP PARAMERTERS .....	22
1.17.1 Set-up parameters programming by SMS.....	23
1.18 SMS MESSAGES EDITOR.....	24
1.18.1 Alarm messages remote editing by SMS command.....	24

1.19 DTMF REMOTE COMMAND TABLE.....	25
1.19.1 Receive all parameters (PALL) .....	26
1.19.2 Receive telephone numbers (PTN).....	26
1.19.3 Receive links (PLN).....	26
1.19.4 Receive input parameters (PIN).....	26
1.19.5 Receive input filter value (PID).....	26
1.19.6 Receive delay before dial value (PDD).....	26
1.19.7 Receive clip identification functions (PTC).....	26
1.19.8 Receive access telephone numbers (PSL).....	27
1.19.9 Receive output parameters (POS).....	27
1.19.10 Receive link for local alarm output (POD).....	27
1.19.11 Receive all programmed SMS messages (P#).....	27
1.19.12 Receive the power level on the unit (PPWR).....	27
1.19.13 Receive set up parameters value (PPA).....	27
1.19.14 State of the credit for the PRE-PAY CARD.....	27
1.19.15 State of the outputs (PORC).....	28
1.20 CHECKING SYSTEM STATUS BY SMS COMMAND.....	29
1.21 CHECKING SYSTEM STATUS BY DTMF COMMAND.....	29
1.22 CHANgING SYSTEM STATUS OFF TO ON (SYSTEM ON).....	29
1.23 CHANgING SYSTEM STATUS ON TO OFF (SYSTEM OFF).....	29
1.24 CHECKING THE INPUT STATUS BY DTMF.....	30
1.25 CHECKING THE INPUT STATUS BY SMS (INS).....	30
1.26 OUTPUTS REMOTE CONTROL BY SMS COMMAND.....	31
1.27 OUTPUTS REMOTE CONTROL BY DTMF COMMAND.....	31



## FOR YOUR SAFETY

Read these simple guidelines. Not following them may be dangerous or illegal. Read the complete user guide for further information.

### **SWITCH ON SAFELY**

Do not switch the unit on when wireless phone use is prohibited or when it may cause interference or danger.

### **INTERFERENCE**

All wireless phones and units may be susceptible to interference, which could affect performance.

### **SWITCH OFF IN HOSPITALS**

Follow any restrictions. Switch the unit off near medical equipment.

### **SWITCH OFF IN AIRCRAFT**

Follow any restrictions. Wireless devices can cause interference in aircraft.

### **SWITCH OFF WHEN REFUELING**

Do not use the unit at a refueling point. Do not use near fuel or chemicals.

### **SWITCH OFF NEAR BLASTING**

Follow any restrictions. Do not use the unit where blasting is in progress.

### **USE SENSIBLY**

Use only in the normal position as explained in the product documentation. Do not touch the antenna unnecessarily.

## FEATURES

- ⇒ Built in GSM module
- ⇒ 2 alarm inputs
- ⇒ 2 remote control alarm outputs
- ⇒ Pre-recorded alarm messages – 1 for each alarm input
- ⇒ SMS for each alarm input
- ⇒ Memory stores up to 4 different telephone numbers
- ⇒ Dialing of telephone number sequences can be programmed
- ⇒ LED displays enable easy monitoring
- ⇒ Already activated dialing sequence can be stopped by means of user's telephone unit
- ⇒ Download programming by SMS
- ⇒ Input and Output status checking by SMS and DTMF command
- ⇒ Outputs remote control by SMS, CLIP and DTMF command
- ⇒ System activating and deactivating by SMS, CLIP and DTMF command
- ⇒ Phone book memory clear by SMS command
- ⇒ Full print out of programming parameters by SMS
- ⇒ Print out by parameters groups (14 groups)
- ⇒ Pre-pay cards credit and value checking
- ⇒ Security protected for incoming calls
- ⇒ Call back device checking Manual fix of the GSM network
- ⇒ Easy new firmware downloads with the ISP programming cable
- ⇒ Event log with the time stamp

## DESCRIPTION

The GSM-VAC4+-GSM is a new kind of a mobile voice and SMS dialing system. The phone memory in the form of a SIM card is used either to store telephone numbers or to program certain parameters. The alarm event is possible send on to 4 different telephone numbers. The alarm inputs can be *normal open* (N.O.) and are thus triggered by a positive (+12V) or a negative pulse (GND); or they can be *normal close* (+12V or GND lost). Each alarm input enables us to send an alarm recorded voice message, the SMS message or both.

The GSM-VAC4+ LITE has also TWO outputs giving the user the ability to control a certain system from distance by DTMF, SMS or CLIP command

## START UP

- ⇒ Insert SIM card to be used for GSM-VAC4+ LITE in your personal mobile phone.
- ⇒ **ERASE THE PIN CODE!**
- ⇒ Enter telephone numbers and the required operating parameters in SIM memory – at least 1 telephone No. (TN1) and 1 link (LN1) should be programmed (see installer's manual)
- ⇒ Insert SIM card in the GSM module applied for the GSM-VAC4+ LITE device. The unit must be power OFF when you insert the SIM!
- ⇒ Connect alarm inputs and outputs to GSM-VAC4+
- ⇒ Connect the antenna to antenna connector
- ⇒ Connect device to source power supply voltage
- ⇒ Wait until LED3 display is turned ON (green) and LED1 (blue) starts flashing. This will be set in around 1 minute time.
- ⇒ Connect the headset to Play/REC connector and record alarm messages
- ⇒ GSM-VAC4+ LITE unit is now ready for operate.

**NOTE:**

**When the back-up battery 12V/0.8Ah is connected on the unit the main power supply must be from 13,8V to 14,5V DC!**



## LED DISPLAY

### **Blue LED (LED1)**

- Indicate the level of the GSM signal from 1-5 LED flash (1 = weak signal, 5 excellent signal)

### **Red LED (LED2)**

- When the LED 2 is ON the unit has a problem with a GSM network connection or the GSM part of the unit is out of order. In this case immediately call the service!

### **Red LED (LED2) – alarm state**

- During alarm event the RED led will indicate on which input alarm is. For example, for the first input you'll see 1 flash, second input 2 flashes etc.

### **Green LED (LED3)**

- When the alarm inputs on the unit are in active state (SYS=1) then the green LED is ON. With inputs disabling the green LED goes OFF (SYS=0).

### **Yellow LED (LED4)**

- Short flashing indicate that the GSM module is ON but it is not yet connect on the GSM network. After connection yellow led flashing with short pulse ON and a long pulse OFF.

## **PURPOSE AND APPLICATION**

The GSM-VAC4+ LITE mobile device can provide us with different information on the state of the alarm mounted on the protected object. It can also transmit other useful information important for operating applications such as:

- ⇒ vending machines
- ⇒ fire systems
- ⇒ security alarm systems
- ⇒ various engines out of the reach of manual operation
- ⇒ home care or emergency alarm
- ⇒ car and boat alarm transmitter
- ⇒ temperature regulation by means of a sensor
- ⇒ industrial control applications

# CONNECTING DIAGRAM

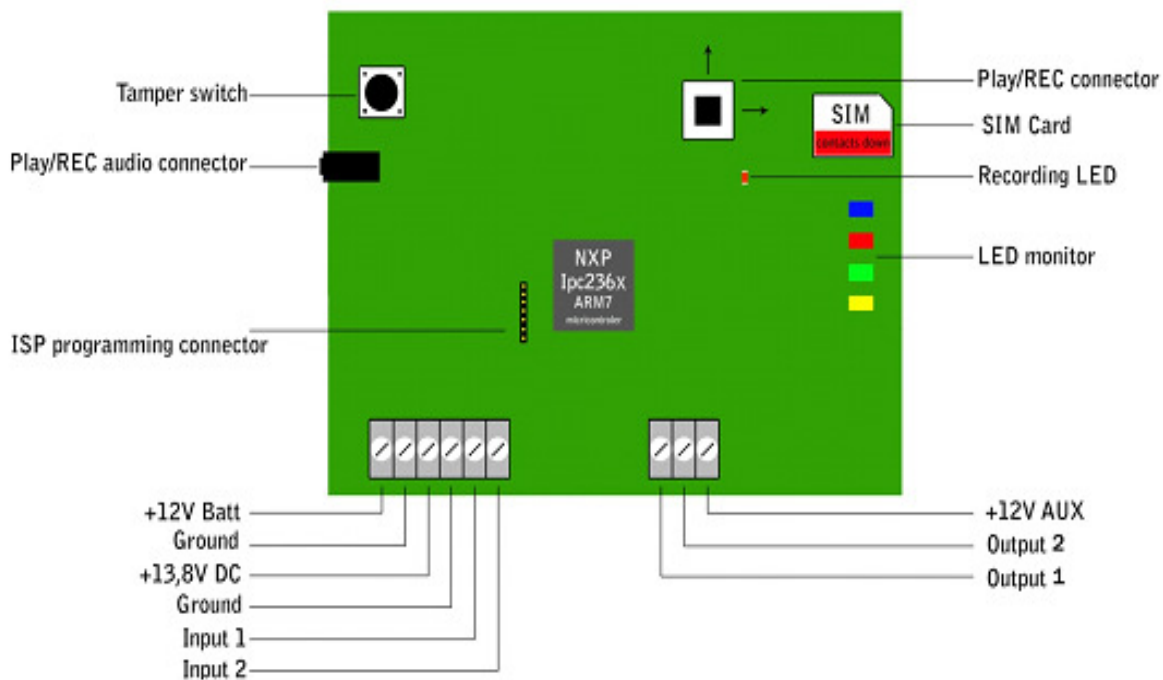

## VOICE MESSAGES – RECORD & PLAY

The memory of each alarm input enables us to record our own voice message in the total length of 10 seconds. The device is namely equipped with a Play/Record audio connector. For recording and listen recorded message the headset is necessary. The headset is very common and it is use with many mobile phones but should be supplied also by your distributor.

### 1.1 RECORDING MODE

For recording and playing alarm messages the unit has a joystick switch which you can use in 2 different directions:

- Message 1 – UP
- Message 2 – RIGHT

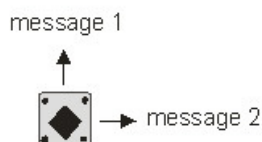

To start recording mode push the Play/REC joystick in to one direction (depending which message you'd like to record) and hold the stick in this position. After the beep you can start with recording and stop recording when you'll here two short beeps. The REC/Play procedure is indicating by REC/Play LED as well. The REC/Play LED will flashing during recording or playing procedure.

Follow the same procedure for all two alarm messages.

### 1.2 PLAY

Press the PLAY/REC joystick into one direction for a short time (around 1 second) and you will hear the recorded message.

To stop play mode press the Play/REC joystick again for a second and play mode will stop.

Follow the same procedure for all two messages.

## GSM-VAC4+ LITE PROGRAMMING MODE

All data, programming values and telephone numbers need to be stored in the phone book located on the SIM card. The GSM-VAC4+ LITE is possible to program on 4 different ways:

- ⇒ Using the USB SIM manager on the PC - recommended
- ⇒ directly on SIM card using personal mobile phone
- ⇒ Remotely by SMS command

**NOTE:**

**The PIN number on the SIM card must be erasing before programming procedure!!!  
Disconnects the power supply from the unit when remove or insert the SIM card!**

### 1.3 PROGRAMMING TELEPHONE NUMBERS - TN

PROGRAMMING TABLE – DIRECT PROGRAMMING ON THE SIM CARD

GSM-VAC4+ LITE- GSM PROGRAMMING TABLE		
SIM CARD PHONE BOOK		
Name	Phone (Number)	Description
TN1		1 <sup>st</sup> telephone number
TN2		2 <sup>nd</sup> telephone number
TN3		3 <sup>rd</sup> telephone number
TN4		4 <sup>th</sup> telephone number

GSM-VAC4+ LITE send an alarm recorded voice message, an alarm SMS message or both. If the corresponding name ends with the letter “V”, when only voice message is sent; and if the name ends with the letter “M”, only the SMS message is sent. When the name ends with letter “D” the unit will be use for listen-In function.

**By pressing the \* you will switch off the redial call for calling number. The remaining numbers will be called as usual.**

**By pressing the # you will switch off all remaining calls.**

Example: When you need sending an alarm voice message and the SMS message to the first telephone number, only alarm voice message to the second one and only an SMS message to the third one. (See the table below.)

GSM-VAC4+ LITE- GSM PROGRAMMING TABLE		
SIM CARD PHONE BOOK		
Name	Number	Description
TN1		1st telephone number (Voice alarm & SMS message)
TN2V	040719479	2nd telephone number (Voice alarm only)
TN3M	040308350	3rd telephone number (SMS text message only)

**1.3.1 TN remote programming by SMS**

For the upper example send the following SMS from the host phone to the GSM-VAC4+ LITE:  
**; TN1=042376678; TN2V=040719479; TN3M=040308350;**

If you want to get the confirmation SMS back then write “+” before SMS command:  
**; +TN1=042376678; TN2V=040719479; TN3M=040308350;**

**1.4 PROGRAMMING INPUT STATUS - IN**

Alarm and reset input can be triggered in 4 different ways. The status of the input can either be normal closed (N.C) or normal open (N.O.) with positive (+ 12V) or negative (GND) voltage. When you need the input feedback information it is possible to get SMS back when input will return from alarm to normal position. (See cap.5.8 – SMS Messages organizer). To get return SMS use IN=4, 5 or 6.

- ⇒ IN = 0 – Normal Open – triggered with negative voltage (GND)
- ⇒ IN = 1 – Normal Close – breaking negative or positive voltage loop
- ⇒ IN = 2 – Normal Open – triggered with positive voltage (+ 12VDC)
- ⇒ IN = 3 – Input disable
- ⇒ IN = 4 = IN = 0 + input reset SMS
- ⇒ IN = 5 = IN = 1 + input reset SMS
- ⇒ IN = 6 = IN = 2 + input reset SMS

**TYPICAL INPUT CONNECTIONS**

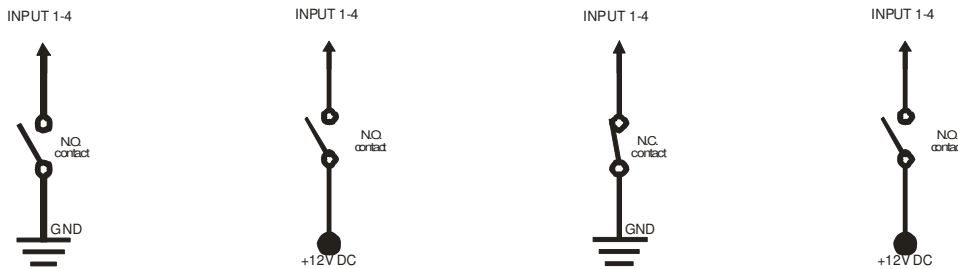

**PROGRAMMING TABLE FOR INPUT STATUS**

GSM-VAC4+ LITE- GSM PROGRAMMING TABLE		
SIM CARD PHONE BOOK		
Name	Default	Description
IN1	0	Input status for alarm input 1
IN2	0	Input status for alarm input 2

Example:

GSM-VAC4+ LITE- GSM PROGRAMMING TABLE		
SIM CARD PHONE BOOK		
Name	Number	Description
IN1	0	Alarm activated by connecting to GND
IN2	1	Alarm activated by disconnecting GND or +12V

**1.4.1 IN parameter remote programming by SMS**

For the upper example send the following SMS from the host phone to the GSM-VAC4+ LITE:

**; IN0=0; IN1=0; IN2=1**

If you want to get the confirmation SMS back then write “+” before SMS command:

**++;IN0=0;IN1=0;IN2=1;**

**1.5 DELAY BEFORE DIAL – DD**

When you want to use some delay before unit will start dialing procedure then you will use DD – delay before dialing parameter.

GSM-VAC4+ LITE- GSM PROGRAMMING TABLE		
SIM CARD PHONE BOOK		
Name	Number	Description
DD1		Delay before dialing for Input 1
DD2		Delay before dialing for Input 2

Example:

GSM-VAC4+ LITE- GSM PROGRAMMING TABLE		
SIM CARD PHONE BOOK		
Name	Number	Description
DD1	5	5 seconds delay before dialing for Input 1
DD2	10	No delay before dialing for Input 2

**1.5.1 DD remote programming by SMS**

For the upper example send the following SMS from the host phone to the GSM-VAC4+ LITE:

**; DD1=5; DD2=0;**

If you want to get the confirmation SMS back then write “+” before SMS command:

**++;DD1=5; DD2=0;**

## 1.6 INPUT FILTER PARAMETR – ID

The ID parameter determine time period of the pulse length to trigger the Input. The pulse time can be from 0, 5 second up to 9999 seconds. The default time is 0,5 seconds when the parameter value is 0.

### 1.6.1 Programming table to define the value of the input filter

GSM-VAC4+ LITE- GSM PROGRAMMING TABLE		
SIM CARD PHONE BOOK		
Name	Number (default)	Description
<b>ID1</b>	<b>0</b>	Default ID filter is 0,5 second – input 1
<b>ID2</b>	<b>0</b>	Default ID filter is 0,5 second – input 2

Example:

GSM-VAC4+ LITE- GSM PROGRAMMING TABLE		
SIM CARD PHONE BOOK		
Name	Number (default)	Description
<b>ID1</b>	<b>0</b>	ID filter is 5 seconds for input 1
<b>ID2</b>	<b>0</b>	ID filter is 30 seconds for input 2

### 1.6.2 ID parameter remote programming by SMS

For the upper example send the following SMS from the host phone to the GSM-VAC4+ LITE:  
**; ID1=5; ID2=30;**

If you want to get the confirmation SMS back then write “+” before SMS command:  
**; +ID1=5; ID2=30;**



### 1.7 PROGRAMMING OUTPUT STATUS - OS

The GSM-VAC4+ LITE device has two open collector outputs and each of them can be programmed through network in a different way: as a bi-stable or mono-stable (pulse) output. The programming time is in seconds.

Typical connection for the output:

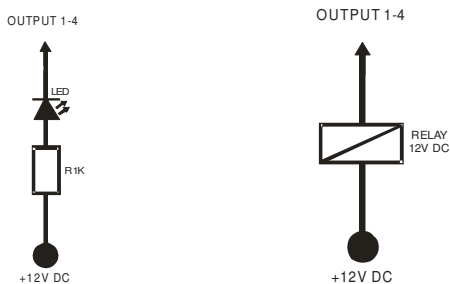

#### 1.7.1 Programming table for output status

GSM-VAC4+ LITE- GSM PROGRAMMING TABLE		
SIM CARD PHONE BOOK		
Name	Number (default)	Description
OS1	1	Status for the 1 <sup>st</sup> output – enabled
OS2	1	Status for the 2 <sup>nd</sup> output – enabled

Example:

GSM-VAC4+ LITE- GSM PROGRAMMING TABLE		
SIM CARD PHONE BOOK		
Name	Number	Description
OS1	1	ON/OFF mode output
OS2	0	Disabled output

#### 1.7.2 OS remote programming by SMS

For the upper example send the following SMS from the host phone to the GSM-VAC4+ LITE:  
**; OS1=1; OS2=0;**

If you want to get the confirmation SMS back then write “+” before SMS command:  
**; +OS1=1; OS2=0;**

## 1.8 DIRECT ALARM OUTPUT – OD

If you want to activate a local alarm (siren) you can program any GSM-VAC4+ LITE output for this function. OD5 to OD8 are links between fictive inputs like telephone line failure, GSM failure to dedicated output.

Type of the Output (ON/OFF or pulse time) is determinate with parameter **OS**.

In the same time you can control the outputs also remotely by SMS or DTMF commands.

Possible programming parameters:

GSM-VAC4+ LITE- GSM PROGRAMMING TABLE		
SIM CARD PHONE BOOK		
Name	Output	Description
OD1		direct connection between input and output
OD2		direct connection between input and output
OD5		System tamper

### 1.8.1 Programming table for OD – direct alarm output

Example:

It is possible to choose different combinations between outputs and inputs

GSM-VAC4+ LITE- GSM PROGRAMMING TABLE		
SIM CARD PHONE BOOK		
Name	Output	Description
OD1	1	Alarm on IN1 trigger output 1
OD2	0	No direct connection between input and output
OD5	2	System tamper on output 2

### 1.8.2 OD remote programming by SMS

For the upper example send the following SMS from the host phone to the GSM-VAC4+ LITE:

**; OD1=1; OD5=2;**

If you want to get the confirmation SMS back then write “+” before SMS command:

**; +OD1=1; OD5=2;**

## 1.9 INPUTS AND TELEPHONE NUMBERS LINKING

It is possible to link each number or any combination of numbers to any of the four corresponding inputs.

**1.9.1 Programming table for linking the inputs and telephone numbers – LN**

GSM-VAC4+ LITE- GSM PROGRAMMING TABLE		
SIM CARD PHONE BOOK		
Name	Number (default)	Description
LN1		Input & telephone No. linking for 1 <sup>st</sup> alarm input (TN1 – TN0)
LN2		Input & telephone No. linking for 2 <sup>nd</sup> alarm input (TN1 – TN0)
LN5		Power down and telephone No. linking (TN1 – TN0)
LN6		Low Battery and telephone No. Linking (TN1 – TN0)
LN7		Periodic test SMS and telephone No. linking (TN1 – TN0)
LN8		SIM card refill and telephone No. linking (TN1 – TN0)
LN9		Tamper switch and telephone No. linking (TN1 – TN0)

Example:

GSM-VAC4+ LITE- GSM PROGRAMMING TABLE		
SIM CARD PHONE BOOK		
Name	Number	Description
LN8	12	Refill SIM – SMS will be send to TN1 & TN2
LN1	13	Input1 will call/send SMS to TN1 & TN2
LN2	123	Input2 will call/send SMS to TN1,
LN7	12	Periodic Test SMS will be send to TN1 & TN2

**1.9.2 LN remote programming by SMS**

For the upper example send the following SMS from the host phone to the GSM-VAC4+ LITE:  
**; LN8=12; LN1=13; LN2=123; LN7=12;**

If you want to get the confirmation SMS back then write “+” before SMS command:  
**; +LN8=12; LN1=13; LN2=123;**

**1.10 MAIN POWER LOST AND TELEPHONE NO. LINKING – LN5**

The GSM-VAC4+ LITE will send an SMS message in case when the main power has been lost. In this case the GSM-VAC4+ LITE will send an SMS to user. The default SMS is “Main Power Lost”. You can also program how many time the unit must be without power before sending this message. The default time is 5 second (parameter MAIN).

**1.10.1 Programming table for the MAIN POWER LOST and telephone numbers linking**

GSM-VAC4+ LITE- GSM PROGRAMMING TABLE		
SIM CARD PHONE BOOK		
Name	Number (Default)	Description
LN5		Telephone number from TN1 to TN0

Example:

GSM-VAC4+ LITE- GSM PROGRAMMING TABLE		
SIM CARD PHONE BOOK		
Name	Number (Default)	Description
LN5	12	Main Power Lost SMS will be send to TN1 and TN2

**1.10.2 LN remote programming by SMS**

For the upper example send the following SMS from the host phone to the GSM-VAC4+ LITE:  
**; LN5=12;**

If you want to get the confirmation SMS back then write “+” before SMS command:  
**; +LN5=12;**

**1.11 LOW BATTERY AND TELEPHONE NO. LINKING – LN6**

The GSM-VAC4+ LITE can control battery level and it will send 3 SMS when reach following voltage level on battery: 11,5V, 10,5V and 9V. It will send the SMS “Low Battery” and battery level in volts together.

The low battery level can be detected when the unit works without main power supply. At the moment when the battery power will be higher than 11,5V the GSM-VAC4+ LITE will send the SMS message with the following text: “Low Battery restored”.

**NOTE:**  
*The “Low battery” will be detected when the GSM-VAC4+ LITE operates only with back-up battery and it is not connected on the Main Power Supply.*

**1.11.1 Programming table for LOW BATTERY and telephone numbers linking**

GSM-VAC4+ LITE- GSM PROGRAMMING TABLE		
SIM CARD PHONE BOOK		
Name	Number (Default)	Description
LN6		Telephone number from TN1 to TN0

Example:

GSM-VAC4+ LITE- GSM PROGRAMMING TABLE		
SIM CARD PHONE BOOK		
Name	Number (Default)	Description
LN6	12	Low Battery SMS will be send to TN1 and TN2

**1.11.2 LN4 remote programming by SMS**

For the upper example send the following SMS from the host phone to the GSM-VAC4+ LITE:  
**; LN6=12;**

If you want to get the confirmation SMS back then write “+” before SMS command:  
**; +LN6=12;**

**1.12 MAIN POWER LOST FILTERLTER PARAMETR - MAIN**

Parameter MAIN determinate length of the pulse which is required to create the alarm after the main power is lost. This time can be from 1 second up to 9999 seconds. The default value is 5 seconds.

For example: When the GSM-VAC4+ LITE will be without main power supply more than 5 seconds (default) then will send the SMS message with following text: “Main Power Lost”.

At the moment when the main power will come back the GSM-VAC4+ LITE will send the SMS message with following text: “Main Power restored”.

**1.12.1 Programming table for “MAIN POWER LOST” filter – MAIN**

GSM-VAC4+ LITE- GSM PROGRAMMING TABLE		
SIM CARD PHONE BOOK		
Name	Number (Default)	Description
MAIN	5	Main Power Lost filter (5 seconds default)

**1.12.2 “MAIN POWER LOST” filter remote programming by SMS**

For the upper example send the following SMS from the host phone to the GSM-VAC4+ LITE:  
**; MAIN=5;**

If you want to get the confirmation SMS back then write “+” before SMS command:  
**; +MAIN=5;**

### 1.13 INPUT TIME WINDOW – IT

The IT parameter determinate the time window within we can trigger (n) alarms (programmed by AR parameter) before the input will automatically blocks. After the IT time the input will be setting free and it will start counting alarm triggers (AR) again. The IT value can be from 1 - 9999 seconds. For example:

Programming table for the input time window – IT

GSM-VAC4+ LITEPROGRAMMING TABLE		
SIM CARD PHONE BOOK		
Name	Number (Default)	Description
IT1	180	Default value for time window is 180 seconds
IT2	180	Default value for time window is 180 seconds

Example:

GSM-VAC4+ LITEPROGRAMMING TABLE		
SIM CARD PHONE BOOK		
NAME	NUMBER	DESCRIPTION
IT1	20	Time window is set on 20 seconds
IT2	75	Time window is set on 75 seconds
IT3	180	Time window is set on 180 seconds
IT4	900	Time window is set on 900 seconds

#### 1.13.1 The input time window remote programming by SMS

For the upper example send the following SMS from the host phone to the GSM-VAC4+ LITE:

**; IT1=20; IT2=75;**

If you want to get the confirmation SMS back then write “+” before SMS command:

**; +IT1=20; IT2=75;**

### 1.14 INPUT TRIGGER COUNTER BEFORE BLOCK - AR

With AR parameter you can program the numbers of the alarm triggers in the time programmed by IT parameter. After (n) alarm triggers in programmed time IT the input will block automatically and will stop calling and sending the alarm SMS.

Programming table for the input trigger counter – AR

GSM-VAC4+ LITEPROGRAMMING TABLE		
SIM CARD PHONE BOOK		
Name	Number (Default)	Description
AR1	5	Default is 5 alarm triggers before input has been blocked
AR2	5	Default is 5 alarm triggers before input has been blocked

Example:

GSM-VAC4+ LITEPROGRAMMING TABLE		
SIM CARD PHONE BOOK		
NAME	NUMBER	DESCRIPTION
AR1	3	The Input has been blocked after 3 alarm triggers
AR2	10	The Input has been blocked after 10 alarm triggers

**1.14.1 The input trigger counter before block remote programming by SMS**

For the upper example send the following SMS from the host phone to the GSM-VAC4+ LITE:

**; AR1=3; AR2=10;**

If you want to get the confirmation SMS back then write “+” before SMS command:

**; + AR1=3; AR2=10;**

### 1.15 SECURITY LEVEL - SL

Which telephone number stored into the phone book from TN1 – TN4 can enter into programming and remote control unit of the GSM-VAC4+ LITE(dialing the GSM-VAC4+ LITE No. or sending the SMS) is defined by SL parameter form SL0 to SL4.

**NOTE: When the SL level is 0, an access to the unit is possible from any phone!**

**NOTE: Before any SL number is programmed the GSM-VAC4+ LITE can accept ALL CALLS. Remote SMS programming and remote controlling is possible from any phone!**

#### 1.15.1 Programming table for security level definition – SL

GSM-VAC4+ LITEPROGRAMMING TABLE		
SIM CARD PHONE BOOK		
Name	Number	Description
SL	0	All calls and SMS will be accepted
SL	1	Only number stored under parameter TN1 has access to unit
SL	2	Numbers stored under parameters TN1 to TN2 have access to unit

#### 1.15.2 SL parameter remote programming by SMS

For the upper example send the following SMS from the host phone to the GSM-VAC4+ LITE:  
**; SL=2;**

If you want to get the confirmation SMS back then write “+” before SMS command:  
**; +SL=2;**



## 1.16 PRE-PAY CARD CREDIT AND VALIDITY INFORMATION

If we use the pre-pay SIM card into the GSM-VAC4+ LITE it is very useful if we can get the information about remain credit.

The GSM providers have different ways to get the credit information. At the moment we can hold up 3 different strings.

**The GSM-VAC4+ LITE will automatically send the low credit SMS when the credit comes below 4€!**

### 1.16.1 Programming pre pay card credit and validity string

GSM-VAC4+ LITE- GSM PROGRAMMING TABLE		
SIM CARD PHONE BOOK		
Name	Number	Description
CC1	*XXX#	* + Number +#
CC2	4916	TIM Italy
CC3	404	Vodafone Italy

CC1=\*448# for SIMOBIL; \*123# for MOBITEL

This method can use all users that get the credit message on this way by GSM phone (press \*+provider number+” & call button).

CC2 method is dedicated to Italian TIM mobile provider.

CC3 method is dedicated to Italian Vodafone mobile provider

### 1.16.2 CC parameter for remote programming

For the upper example send the following SMS to GSM-VAC4+ LITE:

1. CC1 (Simobil) ;CC1=\*448#;
2. CC2 (TIM) ;CC2 =4916;
3. CC3 (Vodafone) ;CC3=404;

### 1.17 GSM-VAC4+ LITESET-UP PARAMERTERS

- ⇒ **CRE** – repetition of calling sequences. With the number from 1 to 99 we define how often the sequence is repeated in case the number is busy or not answered. The default value is set to number “3”.
- ⇒ **HTN** – hidden telephone number. This function (“0” value) is used in order to conceal the telephone number of the GSM-VAC4+ LITE device. The default value is set to “1” which means that the number is displayed.
- ⇒ **SCV** – SIM card validity. The period of valid operating time varies with different GSM network providers. The value can be programmed from 1 to 360 days. The default value does not presume any kind of expiry warning.

After the SIM refill is necessary sending the SMS; SCV=XXX; to the unit and reset the counter.

; SCV=XXX; when XXX are in days which are not the same for all GSM providers. For example in Slovenia SCV are 90 and in Italy 360 days.

**NOTE:**

**The parameter SCV must be sending by SMS command and should not be programmed direct on SIM card!**

- ⇒ **TST** – A test SMS is sent periodically. The GSM-VAC4+ LITE can send the test message in the interval ranging from 1hour up to 240 hours.

Example: if the TST value is set to 12, the numbers linked to “LN7” get a test message every 12 hours.

- ⇒ **MNF** - When is necessary to fix the GSM network to one provider we can use the MNF parameter. The MNF parameter will switch automatic network searching to manual.

For example:

MCC/MNC code for Simobil is 29340, Mobitel is 29341, TIM is 22201, and Vodafone Italy is 22210;

More information's about national MCC/MNC codes you can get here:

<http://www.activexperts.com/activsms/networkcodes/>

- ⇒ **RAN** – Number of rings before GSM-VAC4+ LITE will answer. With this command you can set the ring counter and unit will automatically answer after n ring programmed with this parameter. The default value is 5 rings.

- ⇒ **LNG** – the command will switch between the pre-programmed languages':

Example:

0= English, 1= Italian, 2 = Slovenian, 3 Croatian, 4= Dutch

The default language is English.

Programming table for GSM-VAC4+ LITE Set-up parameters

GSM-VAC4+ LITE- GSM PROGRAMMING TABLE		
SIM CARD PHONE BOOK		
Name	Number	Description
CRE	3	Number of dialing attempts (1 – 99)
HTN	1	Hidden telephone number (1= displayed, 0 = hidden)
RAN	5	Number of rings before answering
SCV	for prepaid SIM	SIM card time validity from 1-360 in days
MNF		Automatic network searching (default)
LNG	0	Switch between different languages'
TST		Periodic test SMS - disabled

Example:

We'd like to change set-up parameters with following values:

GSM-VAC4+ LITE- GSM PROGRAMMING TABLE		
SIM CARD PHONE BOOK		
Name	Number	Description
CRE	2	Number of dialing attempts - 2
HTN	0	Hidden telephone number of the GSM-VAC4+ LITE
RAN	5	The unit will answer after 5 rings
SCV	360	Refill time is 360 days
MNF	29340	Manual fixing of the GSM provider (Simobil)
LNG	1	Switch on Italian language
TST	24	24 hours periodic test SMS

### 1.17.1 Set-up parameters programming by SMS

For the upper example send the following SMS from the host phone to the GSM-VAC4+ LITE:  
**; CRE=2; HTN=0; SCV=360; MFN=29340; TST=24;RAN=5;**

If you want to get the confirmation SMS back then write “+” before SMS command:  
**; +CRE=2; HTN=0; LPA=360; MFN=29340; TST=24; RAN=5;**

### 1.18 SMS MESSAGES EDITOR

You can write and send a short SMS message for each alarm input. The default message is English but the language is possible change with LNG parameter. Each message is build from 3 parts and user can write the first (User Location) and the second (alarm event) part of the message. Unit will add the third part (alarm event description) automatically. The language of the 3rd part may be change by LNG parameter. The message is stored in the SIM phone book so you must add any number for correct operation.

1	2	3	4	5	6	7	8	9	10	11	12	13	14	15	16
#	0	U	S	E	R		L	O	C	A	T	I	O	N	
#	1	I	N	P	U	T		1							
#	2	I	N	P	U	T		2							

**NOTE:**  
 Message should not be longer than 14 characters! Also the space is counted like one character!

#### 1.18.1 Alarm messages remote editing by SMS command

Send the following SMS to the unit:

**;<#0USER LOCATION=0;#1INPUT 1=1;#2INPUT 2=2**

If you want to get the confirmation SMS back then write “+” before SMS command:

**;<+#0USER LOCATION=0;#1INPUT 1=1;#2INPUT 2=2**

## GSM-VAC4+ LITE DTMF REMOTE COMMANDS

**NOTE: If you can't enter into remote mode, check the SL level first!**

### 1.19 DTMF REMOTE COMMAND TABLE

REMOTE COMMAND	ACTION DESCRIPTION
00	All outputs OFF
01	All outputs ON
10	Output 1 OFF
11	Output 1 ON
12	Check the output 1 state (1 beep=ON, 3 beeps=OFF)
20	Output 2 OFF
21	Output 2 ON
42	Check the output4 state (1 beep=ON, 3 beeps=OFF)
51	Input 1 status checking (1 beep=alarm, 3 beeps=normal)
52	Input 2 status checking (1 beep=alarm, 3 beeps=normal)
60	System OFF (3 beeps)
61	System ON (1 beep)
62	System status verification (1 beep=ON, 3 beeps=OFF)
*	Don't call this tel. number again
#	Complete interruption of the dialing procedure

## PRINT-OUT OF THE PARAMETERS

### 1.19.1 Receive all parameters (PALL)

Command; **PALL;**

Sending this command to the GSM-VAC4+ LITE you will get 14 SMS back from it with all parameters that are currently programmed in the unit.

### 1.19.2 Receive telephone numbers (PTN)

Command; **PTN;**

Sending this command to the GSM-VAC4+ LITE you will get back the SMS with all currently programmed telephone numbers (TN1 – TN0).

### 1.19.3 Receive links (PLN)

Command; **PLN;**

Sending this command to the GSM-VAC4+ LITE you will get back the SMS with all currently programmed links (LN1 –LN9).

### 1.19.4 Receive input parameters (PIN)

Command; **PIN;**

Sending this command to the GSM-VAC4+ LITE you will get back the SMS with all currently programmed Input parameters (IN1 – IN4).

### 1.19.5 Receive input filter value (PID)

Command; **PID;**

Sending this command to the GSM-VAC4+ LITE you will get back the SMS with all currently programmed Input filters (ID1 – ID4 and ION).

### 1.19.6 Receive delay before dial value (PDD)

Command; **PDD;**

Sending this command to the GSM-VAC4+ LITE you will get back the SMS with all currently programmed Input filters (DD1 – DD4 and DON).

### 1.19.7 Receive clip identification functions (PTC)

Command ;**PTC;**

Sending this command to the GSM-VAC4+ LITE you will get back the SMS with all currently programmed CLIP function to dedicated telephone number (TN1 – TN0) and number of rings before answer- RAN.

### 1.19.8 Receive access telephone numbers (PSL)

Command ;**PSL**;

Sending this command to the GSM-VAC4+ LITE you will get back the SMS with programmed SL level.

### 1.19.9 Receive output parameters (POS)

Command ;**POS**;

Sending this command to the GSM-VAC4+ LITE you will get back the SMS with all currently programmed Outputs parameters (OS1 – OS4).

### 1.19.10 Receive link for local alarm output (POD)

Command ;**POD**;

Sending this command to the GSM-VAC4+ LITE you will get back the SMS with all currently programmed direct output alarm links (OD1 – OD8).

### 1.19.11 Receive all programmed SMS messages (P#)

Command ;**P#**;

Sending this command to the GSM-VAC4+ LITE you will get back the SMS with all currently programmed alarm SMSs (#0 - #4)

### 1.19.12 Receive the power level on the unit (PPWR)

Sending this command to the GSM-VAC4+ LITE you will get back the SMS with current main power level in volts or current battery voltage when the unit runs on the back-up battery.

### 1.19.13 Receive set up parameters value (PPA)

Command ;**PPA**;

Sending this command to the GSM-VAC4+ LITE you will get back the SMS with all currently programmed Set-up parameters (LPA, TST, CRE, MNF, MAIN...).

### 1.19.14 State of the credit for the PRE-PAY CARD

⇒ CC1

Command ;**PCC1**;

Sending this command to the GSM-VAC4+ LITE you will get back the SMS with Credit amount on your Pre-pay SIM card (for Simobil, Mobitel and Debitel GSM provider).

⇒ CC2

Command ;**PCC2**;

Sending this command to the GSM-VAC4+ LITE you will get back the SMS with Credit amount on your Pre-pay SIM card (for TIM GSM Italian provider).

⇒ CC3

Command ;**PCC3**;

## GSM-VAC4+LITE INSTALLER'S MANUAL

Sending this command to the GSM-VAC4+ LITE you will get back the SMS with Credit amount on your Pre-pay SIM card (for Vodafone GSM Italian provider).

### **1.19.15 State of the outputs (PORC)**

Command ;**PORC**;

Sending this command to the GSM-VAC4+ LITE you will get back the SMS with current outputs state.



## CHECKING AND CHANGING THE SYSTEM STATUS (ON/OFF)

### 1.20 CHECKING SYSTEM STATUS BY SMS COMMAND

Sending this command to the GSM-VAC4+ LITE you will get back the SMS with state of the system.

Command **;SYS;**

The replay SMS can be:

- ⇒ **;SYS= ON;** System is ON (active inputs)
- ⇒ **;SYS= OFF;** System is OFF (inputs are not active)

### 1.21 CHECKING SYSTEM STATUS BY DTMF COMMAND

If you want to check the system status (system ON/OFF) with DTMF command then you should call the GSM-VAC4+ LITE and after beep press command **"62"**. You can hear following response:

- ⇒ 1 beep .....system is ON (all alarm inputs are enable)
- ⇒ 3 beeps.....system is OFF (all alarm inputs are disable)

### 1.22 CHANGING SYSTEM STATUS OFF TO ON (SYSTEM ON)

Sending this command to the GSM-VAC4+ LITE you will switch the system ON.

Command **;SYS=1;**

If you want to get the confirmation SMS back then write **"+"** before SMS command:

Command **;**+**SYS=1;**

### 1.23 CHANGING SYSTEM STATUS ON TO OFF (SYSTEM OFF)

Sending this command to the GSM-VAC4+ LITE you will switch the system OFF.

Command **;SYS=0;**

If you want to get the confirmation SMS back then write **"+"** before SMS command:

Command **;**+**SYS=0;**

## CHECKING THE INPUT STATUS

You can get the information's about inputs status on two different ways:

- ⇒ Call in the GSM-VAC4+ LITE and use DTMF commands
- ⇒ Send the SMS command and get back the SMS with inputs status

### 1.24 CHECKING THE INPUT STATUS BY DTMF

After the short beep press the DTMF command. Response with 1 beep means that the input is in alarm state and response with 3 beep means that the input is in normal (stand-by) state.

<b>51</b>	Input 1 status checking (1 beep=alarm, 3 beeps=normal)
<b>52</b>	Input 2 status checking (1 beep=alarm, 3 beeps=normal)

### 1.25 CHECKING THE INPUT STATUS BY SMS (INS)

Command **;INS;**

Sending this command to the GSM-VAC4+ LITE you will get the replay SMS with all Inputs status. The replay can be:

- ;INS(1-2)=(OPEN-ON) – alarm loop is open and the input is in the alarm state
- ;INS(1-2)=(OPEN-OFF) – alarm loop is open and the alarm input is in the idle state
- ;INS(1-2)=(LOW-ON) – alarm loop is close on GND and the input is in the alarm state
- ;INS(1-2)=(LOW-OFF) – alarm loop is close on the GND and the alarm input is in the idle state
- ;INS(1-2)=(HGH-ON) – alarm loop is close on +12VDC and the input is in the alarm state
- ;INS(1-2)=(HIGH-OFF) – alarm loop is close on the +12V and the alarm input is in the idle state
- ;SYS= ON;
- ;SYS= OFF;

## OUTPUTS REMOTE CONTROL

You can use outputs remote control on two different ways:

- ⇒ calling the GSM-VAC4+ LITE and use DTMF commands
- ⇒ send the SMS command and get back the SMS with outputs status

### 1.26 OUTPUTS REMOTE CONTROL BY SMS COMMAND

Command ;**ORCX=1**;

Sending this command to the GSM-VAC4+ LITE the output X is going ON.

X = output 1-4

Command ;**ORCX=0**;

Sending this command to the GSM-VAC4+ LITE the output X is going OFF.

X = output 1-4

When you want to get the return message with the Output status you must press + before the command. For example:

Command ;**+ORCX=1**;

The return message will be:

**ORCX=(ON)**

### 1.27 OUTPUTS REMOTE CONTROL BY DTMF COMMAND

After the short beep press the DTMF command. Response with 1 beep means that the output is active (ON) and response with 3 beep means that the output is in inactive (OFF) mode.

<b>11</b>	Output 1 ON (bi-stable) or ON for mono-stable
<b>12</b>	Check the output 1 state (1 beep=ON, 3 beeps=OFF)
<b>10</b>	Output 1 OFF (bi-stable) or ON for mono-stable
<b>20</b>	Output 2 OFF (bi-stable) or ON for mono-stable
<b>21</b>	Output 2 ON (bi-stable)

Use 12, DTMF command to verify the output state. With DTMF command “**00**” you may put all outputs **OFF** and with command “**01**” all outputs **ON** in the same time.

## **CLEAR ALL PROGRAMMED DATA FROM SIM**

Command ;**SDCLR**;

Sending this SMS to the GSM-VAC4+ LITE will clear all before programmed parameters and numbers. This is highly recommended when the SIM you'll use for the GSM-VAC4+ LITE is not new and it already has some data stored into the phone book memory.

After this command you should wait at least 30 second for the execution of this command!

**WARNING!!! Sending this command to the GSM-VAC4+ LITE you will erase all programmed data from SIM!**

## CHANGEING PARAMETERS USING THE SMS COMMAND

You can send all programming parameters to the GSM-VAC4+ LITE by SMS command. Each SMS command should start and stop with semicolon. If the confirmation need we must put "+" on the beginning of the command.

The first SMS will be SMS with telephone numbers (TN1 –TN4). After the SMS command; PTN; you'll get following SMS:

**;TN 0=0;TN1=0;TN2=0;TN3=0;TN 4=0;**

You'd like to change the TN0 (040 713 470), TN1 (+38643364850) and TN2 (041255630)

**;TN0=040713470;TN1=+38643364850;TN2=041255630;TN3=0;TN4=0;**

When you put the "+" before SMS command than you'll automatically get the return message with currently programming values.

Example:

SMS to GSM-VAC4+:

**++;TN0=040713470;TN1=+38643364850;TN2=041255630;TN3=0;TN4=0;**

Return SMS from GSM-VAC4+ LITE if you use +:

**;TN0=040713470;TN1=+38643364850;TN2=041255630;TN3=0;TN4=0;**

***NOTE: You can use the same programming procedure for all parameters.***

It is also possible to change just a few different parameters with one SMS. Consider that the SMS should not be longer than **160 characters** (included space characters).

For example, you want to change the following parameters and you want to get the confirmation SMS back:

**TN1, IN1, IN2, OS3, OS4; ID1, LN1 and CRE**

You will create the following SMS:

**++;TN1=+38640713470;IN1=1;IN2=1;OS3=15;ID1=120;LN1=1;CRE=4;**

Send the SMS to the unit's SIM telephone number and in a few seconds you will get the replay SMS. The sentence of the SMS must be the same like original you sent to the GSM-VAC4+ LITE before.

## TECHNICAL SPECIFICATION

Description	Value
Power Supply (without using battery)	9VDC – 25VDC
Power Supply (with connecting battery)	13,8VVDC – 14,5VDC
Current consumption - pick	2A
Current consumption(transmit mode)	350 mA
Current consumption (idle mode)	40 mA
Tri band GSM module	900/1800/1900 MHz
Alarm Inputs	2
ON/OFF Input	1
Alarm and Remote Outputs	2
Alarm recorded voice messages	2
SMS messages	7
PCB dimensions	105 x 80mm
Unit dimensions	118 x 170 x 30 mm
Weight	500g
Antenna SMA	1